



TECHNICAL AND ENGINEERING COMPANY  
ELECTRIC ACTUATOR MANUFACTURER

## Mechanical Data Sheet AP014 & AP028

### Contents

1. SCOPE.....	2
2. REFERENCE DOCUMENTS.....	2
3. ACTUATOR SIZING.....	2
4. QUICK ACCESS TO INFORMATION.....	3
5. MANUAL STRUCTURE.....	4

## 1. SCOPE

This document provides guidance notes about dimensional drawing information.

These notes are applicable to the sizing of the following instrument equipment:

- AP014 Part-turn actuators
- AP028 Part-turn actuators

Any deviation from the present Calculation Notes at any stage of the project shall be subject to manufacturer approval.

## 2. REFERENCE DOCUMENTS

This document is complemented by the others as specified below:

- KSN 8569S310: Mechanical Datasheet
- KSN 8569S311: Technical Specification
- KSN 8569S312: Datasheet

## 3. ACTUATOR SIZING

The sizing of part-turn actuators body will be in accordance with KSN 8569S311.

#### 4. QUICK ACCESS TO INFORMATION

The table below is for actuators with single-phase, 24VDC power and 220VAC-50Hz power input. They work in C type according to EN15714-2.

Model	Operating time to 90° (s)	Course (°)	Nominal Torque (N.m)	Max. torque (N.m)	Maximum start (1/h)	Flange type (ISO5211)	Weight (KG)	IP Protection (EN60529)
AP014a	7.5	0-720	14	20	1500	F03/F04/F05	3.2	IP68
AP028a	12	0-720	28	40	1500	F03/F04/F05	3.2	IP68

The table below is for actuators with single-phase, 24VDC power and 220VAC-50Hz power input. They work in B type according to EN15714-2.

Model	Operating time to 90° (s)	Course (°)	Nominal Torque (N.m)	Max. torque (N.m)	Maximum start (1/h)	Flange type (ISO5211)	Weight (KG)	IP Protection (EN60529)
AP014b	7.5	70-110	14	20	50	F03/F04/F05	3.2	IP68
AP028b	12	70-110	28	40	50	F03/F04/F05	3.2	IP68

The table below is for actuators with single-phase, 24VDC power and 220VAC-50Hz power input. They work in A type according to EN15714-2.

Model	Operating time to 90° (s)	Course (°)	Nominal Torque (N.m)	Max. torque (N.m)	Maximum start (1/h)	Flange type (ISO5211)	Weight (KG)	IP Protection (EN60529)
AP014c	7.5	90	14	20	15	F03/F04/F05	3.2	IP66
AP028c	12	90	28	40	15	F03/F04/F05	3.2	IP66

### 5. MANUAL STRUCTURE

To use a manual wrench, first remove the wrench from the back of the actuator and insert it into the shown part according to the figure.

The manual wrench mechanism has a clutch, and after inserting the special wrench into its shaft, press it down as shown in the figure so that the manual wrench engages with the gearbox and the engine is released from the gearbox.

If the actuator is on, when the manual wrench shaft is pushed down, the motor is automatically disconnected from the circuit with an electro-mechanical mechanism.

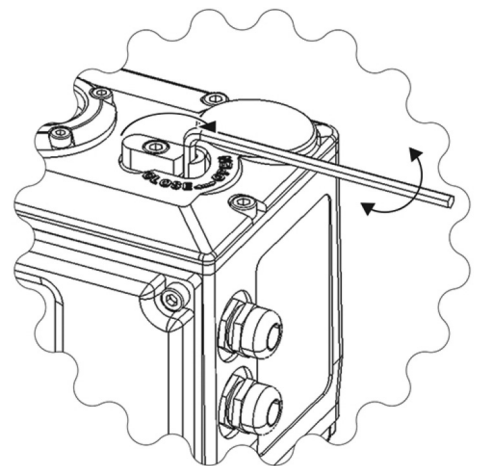
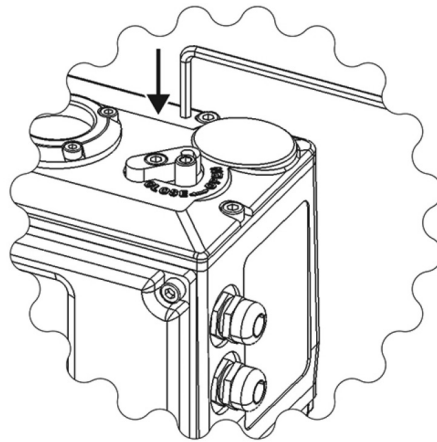

After that, the retaining part of the hand wrench shaft should be turned on it to prevent this shaft from rising.

By turning the wrench, you can open or close the actuator.

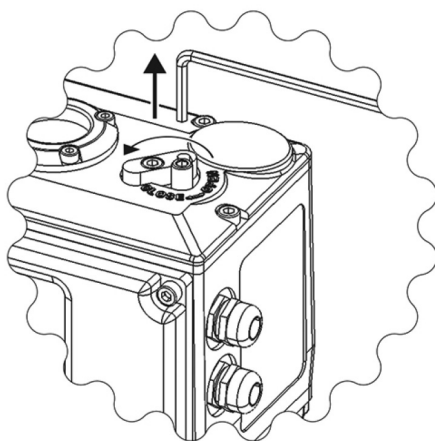

After using the manual wrench, be sure to release the corresponding clutch and for do this:

First, push the shaft down with the same Allen wrench and remove the retaining piece from the shaft.

By removing the wrench, the clutch is released and its shaft rises.

Warning: If the clutch is not released, the actuator motor will not turn on.